



**Advanced infrared
point gas detector**

Searchpoint Optima Plus



Why Infrared?

- Failsafe operation
- Fast speed of response
- Reduced routine maintenance
- Immune to catalytic poisons
- Long operating life
- Works in inert atmospheres

Why Searchpoint Optima Plus is the right choice...

- Experience gained from over 100,000 units installed worldwide
- Improved reliability
- Optional HART® over 4-20mA output
- Can detect a wide range of hydrocarbon gases including solvents
- Increased reliability with no moving parts
- Increased stability from self compensating optics
- Immune to long term component drift
- Remote functional gas test facility
- Certified for North American and European Hazardous areas
- Increased false alarm rejection
- Increased uptime with contaminated optics warning
- Dynamic Heating Control ensures condensation free optics
- No undetected failures
- Improved diagnostics
- Integral event logging
- Reduced power consumption
- Certified to many hazardous area classification schemes including: European (ATEX), UL, CSA, IECEx and more

Market leading point infrared Hydrocarbon gas detector offering proven performance and sensitivity

With over 40 years experience in the design, manufacture, installation and maintenance of point infrared gas detection, Honeywell Analytics currently has a Worldwide installed base of over 100,000 infrared point Hydrocarbon gas detectors in a wide spectrum of applications from light industrial to the most demanding of offshore petrochemical environments.

Searchpoint Optima Plus is an infrared point Hydrocarbon gas detector certified for use in potentially explosive atmospheres. The unit's infrared detection principle offers the fastest speed of response and fail-to-safe operation, ensuring that your plant is compliant, your personnel are protected and your production process can deliver maximum uptime. Reduced routine maintenance, when compared with conventional electro-catalytic based gas detectors, provides low ongoing cost of ownership. The development of advanced internal fault diagnostics and false alarm rejection algorithms ensures that Searchpoint Optima Plus delivers the highest level of operational integrity.

Typical applications include environments that may suffer from the presence of catalytic bead poisons or inhibitors, or where there are harsh environmental conditions forcing increased time between routine maintenance, for example; offshore oil and gas platforms, floating production storage and offloading (FPSO) vessels, tankers, onshore oil and gas terminals, refineries, LNG / LPG bottling plants, gas compressor / metering stations, gas turbine power plants, refineries, solvent printing and coating plants.

Over 100 gas and vapour calibrations are available. For a list of detectable gases and vapours, please contact our Customer Support team or your local distributor.



HART 
COMMUNICATION PROTOCOL

Failsafe Hydrocarbon Gas Detection



1. Optics Block

The 4-channel (dual compensated) optics-block is the heart of the Searchpoint Optima Plus. It is specifically designed to compensate for changes in the external environment similar to 2-channel designs, but also compensates for long term component drift such as infrared sources and detectors. This provides the Searchpoint Optima Plus with the most stable optics design possible.

2. Microprocessor

The microprocessor controls the operation of the Searchpoint Optima Plus. The signal processing and algorithms provide a new dimension in false alarm rejection delivering the highest level of operational integrity.

3. Heated Optics Plus Dynamic Heating Control

Heated optic components, monitored via smart electronics, eliminate condensation build up with power saving features.

4. Remote Gassing Cell

Factory fitting of this optional gassing cell within the optical path allows the remote injection of functional test gas to validate the performance of a Searchpoint Optima Plus.

Remote Gas Sampling Systems

For monitoring remote or inaccessible locations Searchpoint Optima Plus can be fitted with a flow housing and engineered into a gas sampling system. Single-point and multi-point systems are available for both hazardous and non-hazardous areas.

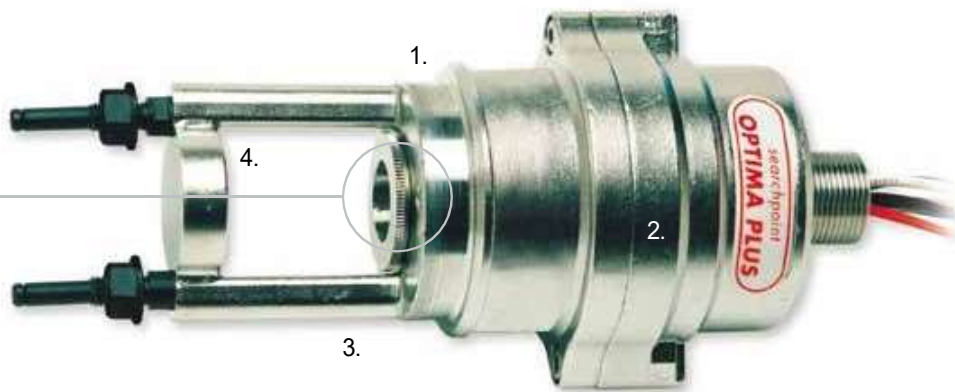

Sunshade / Deluge Protection

This multi-purpose accessory supplied as standard shields Searchpoint Optima Plus from the extremes of operational environments ensuring reliable operation.



Storm Baffle

This optional baffle reduces wind chill, salt and dust build-up in exposed applications subjected to high wind speeds e.g. Offshore HVAC intakes and FPSO turrets etc.



Standard Weather Protection

This accessory supplied as standard, offers the best compromise between water / dust ingress and speed of response.



Dust Barrier

This barrier fitted inside the standard weather protection provides additional protection against the ingress of dust and contamination entering the optical path.



Gassing Cover

The gassing cover enables confidence checking of the Searchpoint Optima Plus. It provides a close fit onto the standard weather protection and can be installed without the use of any special tools.



Calibration Cap

The calibration cap is required to achieve accurate calibration of the Searchpoint Optima Plus.

XXN Universal Transmitter

This device offers a local display and non-intrusive access via a magnetic switch. It has a HART® communications output and optional Modbus, Foundation Fieldbus or relays.



HALO Junction Box

This is an Ex e certified junction box, with an LED light ring to provide a local visual status indication, and an optional non-intrusive HART® interface.



Other Accessories



Duct Mounting Kit

This mounting plate arrangement enables installation of Searchpoint Optima Plus with a duct/ventilation system. It enables functional gas testing without removing the Searchpoint Optima Plus from the ducting system.

Accessories



Field Interrogation



Multi Purpose Hand Held Interrogator (SHC-1)

This versatile commissioning / maintenance tool is certified for hazardous areas and used to reconfigure Searchpoint Optima Plus for different gases and fault diagnostics. The same interrogator can be used with the original Searchpoint Optima and Searchline Excel (open path gas detector) reducing operator training.

Termination / Mounting



Certified Junction Boxes

A full range of hazardous area certified Ex e and Ex d junction boxes are available.



SHC-1 Protection Device

This device provides electrical protection for the SHC-1 when used with conventional terminal housings under a gas free permit to work system.

HART[®] COMMUNICATION PROTOCOL

HART[®]: Reduce your operational costs and gain enhanced device visibility

Searchpoint Optima Plus is available with HART[®] over 4-20mA output. This communication aspect allows Searchpoint Optima Plus to deliver a wide range of added value benefits.

What is HART[®]?

HART[®] (Highway Addressable Remote Transducer) is a widely used digital communications protocol, which allows users to access live data, status indications and diagnostic information from intelligent field devices. It works by superimposing a digital signal on the existing analogue signal. A key benefit of HART[®] is the fact no additional field cabling is required, because HART[®] uses the device's 4-20 mA signal cable. HART[®] can also help to reduce costs in a number of ways. For example, it eliminates the need for proprietary handheld devices; a field engineer can use a single HART[®] handheld device to access any HART[®] enabled equipment on site. The HART[®] signal can be interrogated from anywhere in the current loop, and this means that users can access diagnostic information without going into the field. This means that if maintenance is required, the scope of work is known before the engineer goes to the device, potentially helping to reduce ongoing maintenance costs.

Searchpoint Optima Plus' HART[®] interface speaks the language of gas detection

Searchpoint Optima Plus' HART[®] user interface is designed for gas detection using familiar terminology. Honeywell Analytics' engineers have designed the Device Description (DD) file to provide easy to understand messaging on HART[®] host devices, guiding the user through operations and eliminating time wasted referring to manuals to "decode" generic HART[®] messages.

Searchpoint Optima Plus and its DD file are registered with the HART[®] Communication Foundation, having passed the Foundation's rigorous test program.

Available functions:

- View gas reading, configuration and diagnostic information
- Bump test
- mA loop calibration
- Gas calibration
- Simulate alarm, fault or warning
- Set device tag, ID and description
- View active warnings / faults and event history
- Force mA output to a set level for testing
- Configure real time clock
- Configure inhibit, warning and overrange levels
- Configure alarm threshold
- Change target gas
- Password protected access

Benefits of using HART[®]

- Access full information from Searchpoint Optima Plus, anywhere in the current loop
- No associated infrastructural costs, unlike some other communications protocols; additional communication is achieved without the need for extra cabling
- Save on set up costs by eliminating the need for proprietary handheld devices
- Save on long-term costs by enabling proactive not reactive maintenance
- Save a field engineer investigation trip - "know before you go"

Technical Summary



Searchpoint Optima Plus Specification

Measuring Range	0-100% LEL, wide selection of Hydrocarbon gas and vapour calibrations. Different measuring ranges and solvent calibrations available for specialist applications	
Signal Output	4-20mA autosensing sink or source	
Inhibit	1-3mA (Default 2mA)	
Warning	0-6mA (Default 3mA *)	
Fault	0mA (HART® units adjustable to 1mA)	
Over Range	20-21.5mA (Default 21mA)	
Digital Output	Optional Multidrop Modbus RS485 (via XNX, Optional HART® over 4-20mA output (HART® version 7)	
Material	316 stainless steel	
Weight	1.6kg	
Accuracy	Optima Plus (Hydrocarbon) Baseline < ±1% FSD, 50% FSD <±2% FSD Optima Plus (Ethylene) Baseline < ±2% FSD, 50% FSD <±3% FSD	
Repeatability	< ±2% FSD at 50% FSD	
Linearity	< 5% FSD	
Response Time	T50 < 3 seconds, T90 < 4 seconds (methane)	
Operational and Certified**	-40°C to +65°C temperature range **CU-TR-EX (Russia) Approval – XTC Version, Certified Temperature Range -60°C to + 65°C	
Long Term Stability (as defined in EN 60079-29-1)	Baseline	Methane 100 %LEL Range: ≤ ± 2 %FSD Ethylene 100 %LEL Range: ≤ ± 4 %FSD
	50 %FSD	Methane 100 %LEL Range: ≤ ± 4 %FSD Ethylene 100 %LEL Range: ≤ ± 5 %FSD
Drift Over Temperature Range (-40 °C to 65 °C)	Baseline	≤ ± 2 %FSD
	50 %FSD	Methane 100 %LEL Range: ≤ ± 0.131 %FSD per °C Ethylene 100 %LEL Range: ≤ ± 0.078 %FSD per °C
Variation with Pressure	0.1% (of reading) per mbar	
Power Supply	18-32Vdc (24Vdc nom), < 4.5W max	
Environmental Protection	IP 66 / 67	
Diagnostics (and Re-calibration)	Via certified Hand-held Interrogator, XNX or optional HART® communications	
Safety Approvals	ATEX: Baseefa13ATEX0296X II 2 GD Ex d op is IIC Gb Ex tb IIIC Db T96°C (T _{amb} -40°C to +65°C) T86°C (T _{amb} -40°C to +55°C) IP 66/67 UL / CSA: Class 1, Div 1, groups B, C, and D (-40°C to +65°C) IECEx: II 2 GD Ex d op is IIC Gb Ex tb IIIC Db T86°C (T _{amb} -40°C to +55°C) or T96°C (T _{amb} -40°C to +65°C) IP66/67 CU-TR-EX (Russian Customs Union) - XTC Version 1Ex d op is IIC T5/T4 Gb X (T _{amb} -60°C to +65°C)	
Performance Approvals	EN 60079-29-1 (BVS 03 ATEX G 016 X), CSA C22.2 152., FM ANSI/ISA-12.13.01., Russian Pattern Approval (Metrology) - XTC Version ***	
Functional Safety	IEC61508 Safety Integrity Level 2	
EMC Compliance Software	EN 50270:2006 EN 50271:2010	
Marine Approvals	Marine Equipment Directive (MED), type approvals from DNV, BV, ABS, Lloyd's Register	
	* Note for ATEX compliance the warning value should not be set between 3 and 5mA *** Please refer to manual for full information	

Installation Options

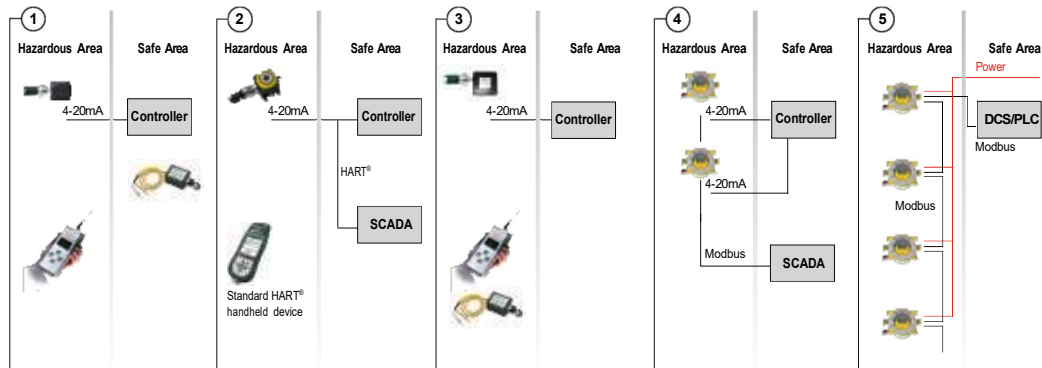

Honeywell Analytics Gas Detection



Honeywell Analytics is able to provide gas detection solutions to meet the requirements of all applications and industries. Contact us in the following ways:

Locally available from:



SWIFT MARINE TECH SERVICES PTE LTD

Honeywell Analytics
Experts in Gas Detection



Please Note:

While every effort has been made to ensure accuracy in this publication, no responsibility can be accepted for errors or omissions. Data may change, as well as legislation, and you are strongly advised to obtain copies of the most recently issued regulations, standards, and guidelines. This publication is not intended to form the basis of a contract.

11257_H_Searchpoint Optima Plus_DS0276_V11_EMEA

06/15

© 2015 Honeywell Analytics

Honeywell