

Preliminary Checklist Before On-boarding Service

KSB Seil Co., Ltd.

76 Noksansaneopbuk-ro 313beon-gil, Gangseo-gu, Busan, Korea

Tel +82 51 831 1858

E-MAIL: ksbseil_service@ksb.com

Website: <https://www.ksb.com/en-kr/company/ksb-seil-co-ltd>



Vessel Name		ODME Version (Refer to last page)	
IMO No.		Hull No.	
Shipyard			
Ship Owner/Title			
Customer's Email/Tel			

Controller

Controller Display	Any alarm is displayed on controller?	(Yes / No)
	If yes, please remark which alarm is displayed.	
Print log	Please check if there is any alarms record. (One month)	(Yes / No)

Transmitter

Transmitter Display	Flowrate value is displayed in controller while the transmitter is operating?	(Yes / No)
	Installation condition is good without any leakage?	(Yes / No)
Transmitter	If any leakage is observed, please mark leakage point on the drawing below	

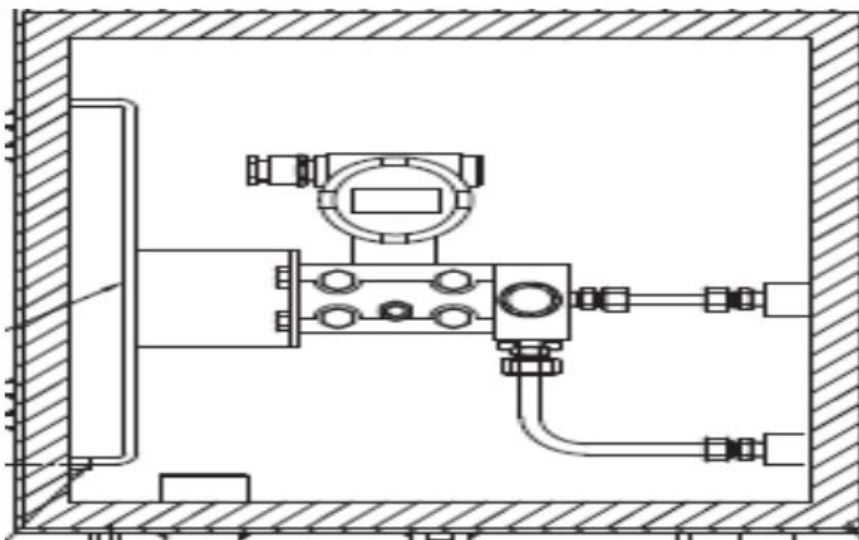

Preliminary Checklist Before On-boarding Service

Hydraulic panel and Pump

Hydraulic Panel	Installation condition is good without any leakage?	(Yes / No)
	If any leakage is observed, please mark leakage point on the drawing below.	
Pump	Installation condition is good without any leakage?	(Yes / No)
	If any leakage is observed, please mark leakage point on the drawing below.	

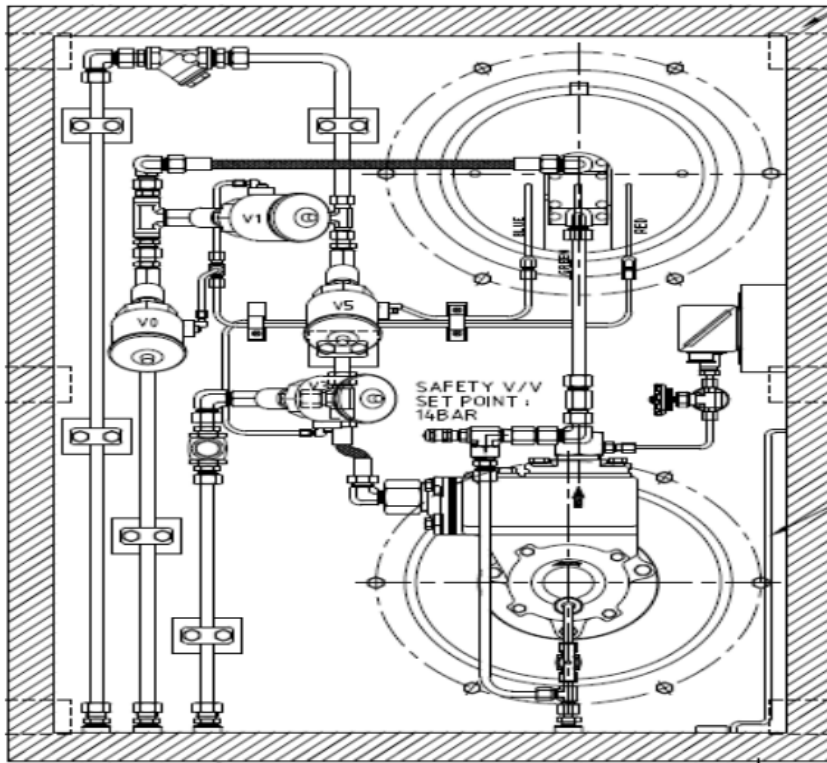

Visual inspection

Is there any damage to the ODME equipment or any problems? If there is please write it down.

Checked by _____

S-3000 – Oil Discharge Monitoring Equipment

Ver.1



Oil Discharge Monitoring Equipment S-3000 Ver.2

