



EMx40

Maintenance Manual

Radar System Maintenance Manual

EMx40

*1st Edition
Released February 2013*

INTRODUCTION

This manual is issued specifically for the EMx40 system transmitters. It contains instructions detailed for the installation of this system.



To use it in an optimal way, we advise you **TO READ CAREFULLY THESE INSTRUCTIONS** and to respect them throughout the life of the equipment.

Keep this manual to hand so that you can refer to it at any time. Ensure that it is complete and kept close to the equipment.

The EM540 or EM940 radar, T901-P transmitter and LOG3840 indicator are integrated in the system for processing the tankers liquid cargo. This system is intended for professional use, it must be used by operators who are qualified and well-versed in the operating rules and safety instructions set out in this manual.

We also draw your attention to the fact that the connection of equipments or the use of products other than those recommended by **Honeywell Marine** may present risks for which we will not be liable.

This manual must not be reproduced in any form whatsoever without the prior written approval of **Honeywell Marine** who cannot be held responsible for any use of the information contained in this manual.

As we want you to take advantage of the most of the latest technology and new equipment, as well as to benefit from our experience, our equipments may undergo technical or design changes. As a result, some of the features and information in this manual may change without prior notice and without any obligation to up-date it.



Pictures of this document are not contractual.

Should you encounter any problems or have any questions about your EMx40 system, please do not hesitate to contact your nearest **Honeywell Marine** customer service

Other documents

■ The description and operation of EMx40 system transmitters are described in the MT5016E technical manual.

■ The maintenance of EMx40 system transmitters is described in the MM5016E maintenance manual.

■ The description and operation of the racks TA3840C/R and TA3840S for measuring data collection are described in the MT5008E technical manual.

SAFETY PRECAUTIONS:



Current regulations and legislation applicable to hazardous areas must imperatively be known and followed by personnel responsible for installing, commissioning and operating and intrinsically safe equipment.

Take care to switch the power off before proceeding to any disconnection or removal of the transmitters.

**WARNING:**

Our equipments are designed and manufactured in accordance with local safety regulations, and in particular European directives relative to reconciling member states' legislation:

- 89/336/EEC and 2004/108/EC "Electromagnetic compatibility",
- ATEX 94/9/EC "Equipment and protective systems intended for use in potentially explosive atmospheres",
- 96/98/EC "Marine equipment".

The EM540, EM940 radar and associated transmitters are certified for use in hazardous area according to the intrinsic safety protection type. Examination certificates are supplied in appendix.

They are intended for professional use and must be installed, used and maintained by competent staff who are qualified in this type of equipment.

In particular we wish to draw your attention to the fact that we cannot be held responsible if:

- Any technical alterations are made to our appliances without our written authorisation,
- Our equipments are damaged by being operated in conditions other than the intended usage of their technical classification (power supply, temperature, environment, etc.).

The safety instructions given in this manual are merely given for guidance purposes to protect you and all those using and working on our equipments. **Honeywell Marine** cannot foresee all dangerous situations that might arise. This is why the owner and/or the operator is responsible for the operating safety of the system.

Regulations of the ship classification society may impose procedures (health and safety, fire prevention, handling of hazardous substances, etc.) which are stricter than those given in this manual. In this case, the regulations must be followed.



EM540

IDENTIFICATION NAMEPLATE
II 1(1) G
Ex ia [ia Ga] IIB or IIC T4 Ga
LCIE 05 ATEX 6087X
IECEX LCIE 12.0009X

MARKING
S/N
P/N
TAG



EM940

IDENTIFICATION NAMEPLATE
II 1(1) G
Ex ia [ia Ga] IIB or IIC T4 Ga
LCIE 05 ATEX 6087X
IECEX LCIE 12.0009X

MARKING
S/N
P/N
TAG

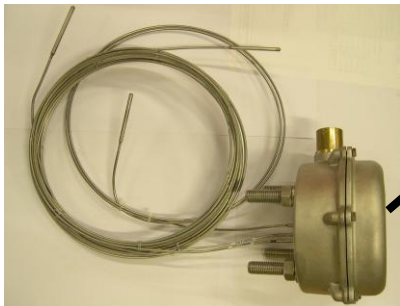

T901-P

IDENTIFICATION NAMEPLATE
II 1 GD
Ex ia IIC T6 Ga
Ex ia IIIC T80°C Da IP66/67
LCIE 03 ATEX 6246X
IECEX LCI 11.0039X

MARKING
S/N
P/N
TAG

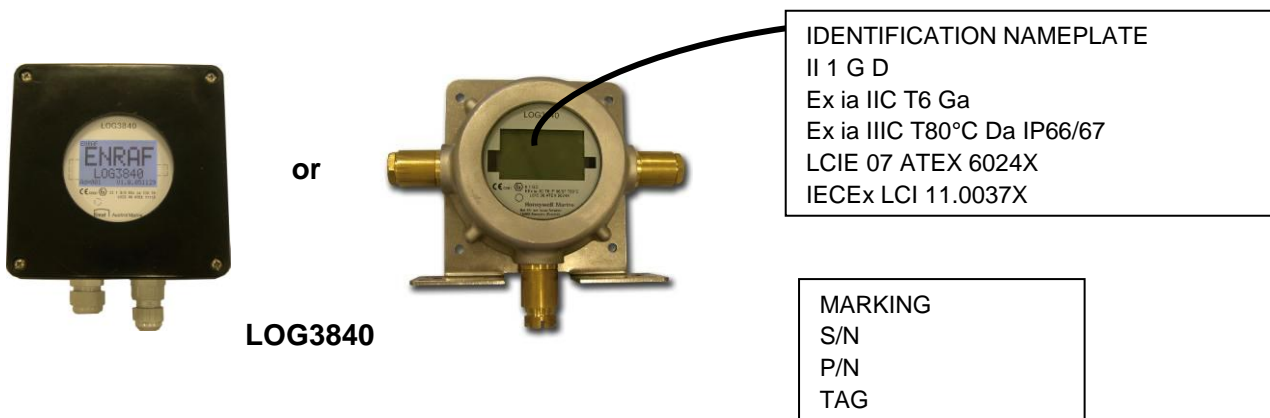
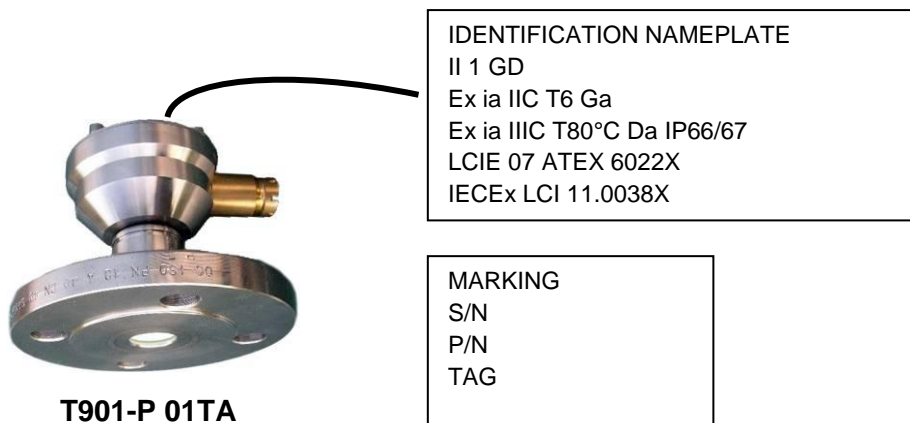
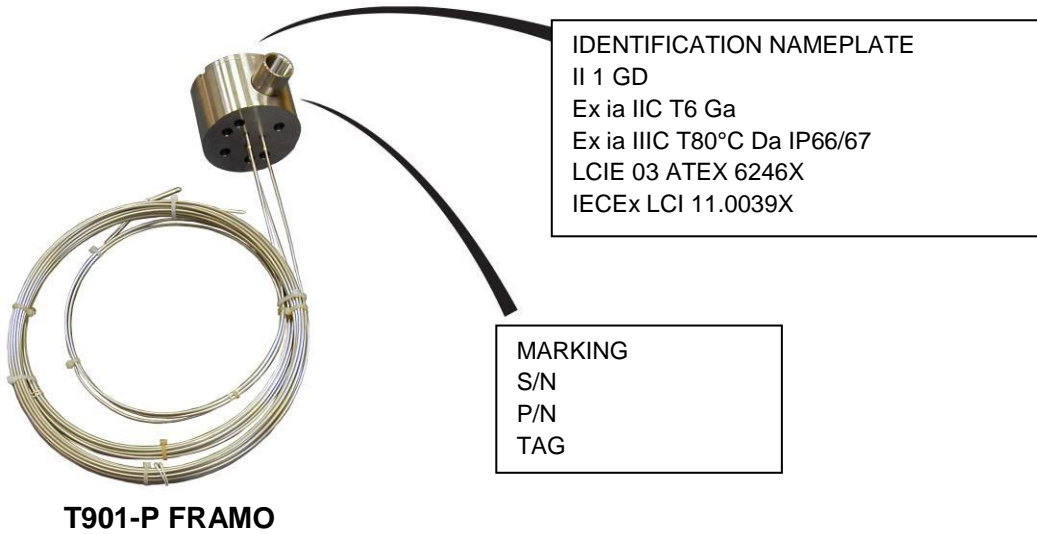

TABLE OF CONTENTS

1. SYSTEM DESCRIPTION	8
2. PREVENTIVE MAINTENANCE	9
3. TROUBLESHOOTING GUIDE	9
EMx40 radars	9
T901-P temperature/pressure transmitter	10
LOG3840 deck digital indicator	10
4. REMEDIAL MAINTENANCE	11
EMx40 radars - Repair procedures	11
EM940 radar antenna cleaning	12
EM540 V3.00 or EM940 connecting board replacement	12
EM940 pressure sensor calibration	13
EMx40 radar replacement	13
Temperature sensor replacement	14
Pressure sensor calibration on universal model	15
Pressure sensor calibration on pressure measurement model	16
Pressure sensor replacement	16
Electronic module replacement	17
5. SPARE PARTS LIST	19
EMx40 radars	19
T901-P temperature/pressure transmitter	20
LOG3840 deck digital indicator	20
6. INFORMATIONS	21
Claim report	21
Return for repair	21
7. APPENDIX A - EMx40 SYSTEM / CLAIM REPORT	22
8. APPENDIX B – EMx40 SYSTEM / RETURN FOR REPAIR FORM	23

Storage

There is no particular requirement. The storage temperature of the EMx40 system transmitters is 0 °C to +70 °C.

1. SYSTEM DESCRIPTION

The EMx40 level radar transmitters, T901-P temperature/pressure transmitters and LOG3840 deck digital indicator are parts of the EMx40 system, dedicated to monitor the tankers liquid cargo parameters such as level, temperature and pressure, as well as all associated measurements. They are installed in hazardous area.

General description and operation of the EMx40 system transmitters are described in the MT5016E technical manual.



**EM940
radar**



**T901-P
temperature/pressure**

or



**T901-P F
temperature transmitter**

or



**T901-P 01TA
pressure transmitter**



**EM540
radar**



or



**LOG3840
deck digital**



SAFETY INSTRUCTIONS:

We cannot be held responsible for damage caused directly or indirectly by faulty maintenance.

Maintenance intervention must be carried out with electrical power off on supply lines.

2. PREVENTIVE MAINTENANCE

To guarantee a long life for your system, it is very important to check regularly, at least every 3 months:

- The tightness of cable entries on each transmitter of the EMx40 system,
- The cleanliness of the radar antenna,
- The correct tightening of the terminal box covers.

If the terminal box cover is opened, check the gasket condition and change it if necessary (refer to the spare parts list).



If a packing-gland is dismantled, imperatively replace the sealing ring (refer to the spare parts list).

If a radar fitted with a appropriateE gasket is removed, imperatively replace the gasket (refer to the spare parts list).

3. TROUBLESHOOTING GUIDE

If the system starts a system alarm at the communication unit (see “System alarms” paragraph of the MT5008E technical manual), first search and solve the problem cause outside of the transmitters:

- Consult the “Troubleshooting guide” paragraph of the MM5008E maintenance manual.
- Make sure there is no supply fault of the radar transmitters by checking the radar power supply indicators on the TA3840S or TA840-I safety unit.

When the preliminary checks did not provide a solution to the problem, each of the system transmitters will need to be checked following the instructions in the table below.

EMx40 radars

Observation	Likely cause	Remedy
Faulty measurement (a few tens of cm) or measurement lost	Dirty antenna	Clean the antenna (*).
	Radar transmitter out of service	Replace the radar transmitter (*).
Error message "Wrong" or "LowS" on level measurement	Dirty antenna	Clean the antenna (*).
	Insulation loss by water infiltration in the terminal box	Dry the terminal box. Check the terminal box tightness, and replace the gasket if necessary. Check the cable connection tightness, and replace the packing-gland if necessary.
Communication fault after checking the safety unit according to MM5008E maintenance manual	For the EM540 V3.00 or EM940 radar, the connecting board is corroded by water infiltration.	Replace the connecting board (*).
	Radar transmitter out of service	Replace the radar transmitter (*).

(*) refer to the relevant paragraph in “REMEDIAL MAINTENANCE” chapter.

T901-P temperature/pressure transmitter

Observation	Likely cause	Remedy
Measurement of one of the temperatures faulty or out of range	Defective temperature sensor	Replace the relevant temperature sensor (*).
Faulty temperature measurement and/or faulty pressure measurement	Insulation loss by water infiltration in the terminal box	Dry the terminal box. Check the terminal box tightness, and replace the gasket if necessary. Check the cable connection tightness, and replace the packing-gland if necessary.
	Insulation loss by water infiltration in the terminal box and corroded component	Dry the terminal box. Check the terminal box tightness, and replace the gasket if necessary. Check the cable connection tightness, and replace the packing-gland if necessary. Replace the relevant component (*).
Temperature out of range	Radar transmitter defective input	Replace the temperature sensor by a 100 Ω - 3 wires resistor (available in the test and calibration kit, dedicated for temperature sensor calibration). If the value is different from 0 °C ± 2 °C on the monitor, replace the radar transmitter (*).
Faulty pressure measurement (a few tens of mbar)	Not correct calibration	Check the calibration (*).
Pressure out of range	Defective pressure sensor	Replace the pressure sensor (*).

(*) refer to the relevant paragraph in “REMEDIAL MAINTENANCE” chapter.

LOG3840 deck digital indicator

Observation	Likely cause	Remedy
Cracked glass	Shock on the glass	Replace the cover or the body fitted with its glass, depending on the model (*).
Screen backlight off (if activated when installing)	Defective electronic module	Replace the electronic module (*).
Erratic reading	Insulation loss by water infiltration in the casing	Dry the terminal box. Check the terminal box tightness, and replace the gasket if necessary. Check the cable connection tightness, and replace the packing-gland if necessary.
No display or aberrant displayed value	Defective electronic module	Replace the electronic module (*).

(*) refer to the relevant paragraph in “REMEDIAL MAINTENANCE” chapter.

4. REMEDIAL MAINTENANCE



SAFETY INSTRUCTIONS:

We cannot be held responsible for damage caused directly or indirectly by faulty maintenance.

The equipments must be wired up by a qualified electrician. The mains connection, grounding and protection must comply with the standards and regulations in force, in order not to compromise the intrinsic safety.

Maintenance intervention must be carried out with electrical power off on supply lines.

EMx40 radars - Repair procedures



Check the On/Off switch on the TA3840S safety unit front panel is in "Off" position (or TA840-I safety unit for the TA840 system).

EM540 radar antenna cleaning

If the trunk is fitted with a cleaning hatch, the antenna surface can be cleaned without dismantling the radar.

- Open the hatch, after making sure that the tank is free of inert gas pressure.
- Clean the antenna surface with a damp wiping cloth.
- Close the hatch, taking care with the gasket.

When not fitted with a cleaning hatch, it is necessary to remove the radar from its socket.

- Unscrew the 4 M20 x 100 stainless steels bolts, using a 30 mm wrench, after making sure that the tank is free of inert gas pressure.
- Lift the radar, take care at the flat gasket.
- Clean the antenna surface with a wiping cloth.



In order to avoid any electrostatic charge, use only a damp cloth.

- Refit the radar (refer to the "Installation" chapter of the MI5016E installation manual).



Check the condition of the flat gasket located between the radar and the socket. If necessary, change it.

If the radar is fitted with a PTFE gasket, imperatively replace the gasket (refer to the spare parts list).

EM940 radar antenna cleaning

A pivot hinge is installed between the socket and the radar, making the antenna easy to clean.

- Unscrew the 6 M20 x 80 stainless steels bolts, using a 30 mm wrench, after making sure that the tank is free of inert gas pressure.
- Pivot the radar, take care at the flat gasket.
- Clean the antenna surface with a wiping cloth.



In order to avoid any electrostatic charge, use only a damp cloth.

- Refit the radar (refer to the "Installation" chapter of the MI5016E installation manual).

Check the condition of the flat gasket located between the radar and the socket. If necessary, change it.

If the radar is fitted with a PTFE gasket, imperatively replace the gasket (refer to the spare parts list).

EM540 V3.00 or EM940 connecting board replacement

- Remove the terminal box cover, using a 10 mm wrench.
- Disconnect the wires and note down their location in order to be sure to reconnect them in the correct order.
- Remove the pressure sensor, if present, after closing its valve.
- Unscrew the two nuts fixing the board in the bottom of the box, with a 7 mm wrench.
- Unscrew the 4 fixing screws of the white plate, using a 2.5 mm hexagonal key.
- Remove the board, take care to preserve the rectangular gasket, or replace it if necessary.
- Install a new board by operating in reverse order.
- Install the pressure sensor, if present, reconnect it and open the isolating valve.



Valve for pressure sensor

Nuts

White plate

To close the terminal box, check the flat gasket is in correct position. If necessary, put again some silicone grease on it, with fingers.

Place the cover in correct position and screw the 6 hexagonal head screws, using a 10 mm wrench. **TORQUE 5 N/m**

EM940 pressure sensor calibration

This calibration is to be carried out with the "Test and calibration kit" described in the MT5023 manual.

- Remove the terminal box cover, using a 10 mm wrench.
- Close the internal isolating valve.
- Unscrew the 2 fixing screws of the pressure sensor, using a 4 mm hexagonal key.
- Remove the pressure sensor, without disconnecting it.



Take care not to knock the ceramic diaphragm of the sensor.

- Proceed as for the T901-P universal model pressure sensor calibration, page 14
- After calibration, install the sensor and its gasket.

Note: install carefully the gasket in its groove.

- Open the internal isolating valve.
- Close the terminal box cover by screwing the 6 screws, take care at the sealing gasket. **TORQUE 5 N/m**

EMx40 radar replacement



Make sure that the new radar is delivered by Honeywell Marine with the pre-set parameters related to the tank from which the radar is to be replaced.

- Remove the terminal box cover, using a 10 mm wrench. Disconnect the installed cables in the reverse order than the electrical connection procedure described in the MI5016E installation manual.

Note down the location of the wires, in order to be sure to reconnect them in the correct order.



- Unscrew the 6 (4 on EM540 radar) M20 stainless steel bolts, using a 30 mm wrench.
- Unscrew the 2 M10x20 stainless steel screws of the hinge upper plate, for the EM940.
- Lift the radar.
- Fit the new radar (refer to the "Installation" chapter of the MI5016E installation manual).



Check the condition of the flat gasket located between the radar and the socket. If necessary, change it. If the radar is fitted with an appropriate gasket, imperatively replace the gasket (refer to the spare parts list).

- Reconnect the cables and close the terminal box cover (refer to the "Electrical connection" chapter of the MI5016E installation manual). **TORQUE 5 N/m**

T901-P transmitter - Repair procedures



Check the On/Off switch on the TA3840S safety unit front panel is in "Off" position (or TA840-I safety unit for the TA840 system).

Temperature sensor replacement

- Remove the 6 fixing screws from the removable cover, using a 10 mm wrench (universal model).
- OR
- Unscrew the slotted removable cover with a dia. 8 mm rod (pump body model).
 - Identify the faulty sensor :
 - High (mark H),
 - Middle (mark M),
 - Low (mark L).
 - Cut the plastic collars maintaining the electrical wires.
 - Disconnect the three electrical wires from the terminal.
 - Unscrew the cap using a 13 mm flat wrench.
 - Gently pull the sensor, taking care not to damage the other sensors during the extraction.
 - Take the new sensor and cut the collars maintaining the sensor tube (except those specified hereunder).

Note: the gland and the cap are maintained on the sensor end by two plastic collars. Do not cut them now.

- Engage the new temperature sensor by successive sections straightened by hand in the hole, in order to avoid any constraint in the protecting tube.



Do not bend the tube under a diameter of 250 mm.

- Proceed such until complete introduction of the sensor.
- With one hand, maintain firmly the sensor tube, then with the other hand, cut the lower plastic collar to release the gland.



Take care not to slip out the sensor tube, because the sensor may fall in the tank. Do not take it by the electrical wires.

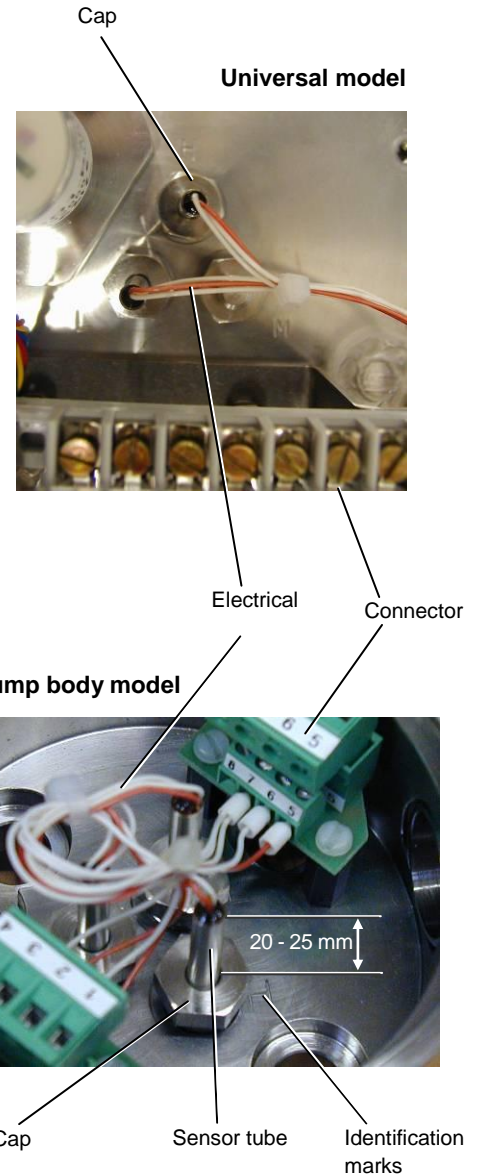

- Position the gland in the conical seat.
- Screw the cap by hand while preserving a height of 20 to 25 mm for the sensor tube over the cap.
- Screw the cap to compress the gland. The absolute leakproofness is reached with a max. tightening torque of 2.5 m.daN.
- Cut the last plastic collar.
- Connect the wires to the terminal, following the T901-P transmitter terminal wiring diagram in the MI5016E installation manual.
- Install two plastic collars to maintain the sensor wires, to avoid jamming them when closing the cover.
- Check the sealing O-ring is in correct position in the groove. If necessary, put again silicone grease on it, with fingers.
- Place the cover in good position and screw the 6 hexagonal head screws or screw the slotted removable cover with a dia. 8 mm rod.

Pressure sensor calibration on universal model

This calibration is to be carried out with the "Test and calibration kit" described in the MT5023 manual.

- Remove the 6 fixing screws of the terminal box cover, using a 10 mm wrench.
- Unscrew the 2 fixing screws of the pressure sensor, using a 4 mm hexagonal key.
- Remove the pressure sensor, without disconnecting it.



Take care not to knock the ceramic diaphragm of the sensor.

- Install the sensor on the T29195 tool of the kit.
- Connect this tool output on the pneumatic calibrator, using the transparent tube.
- Supply with a pressure corresponding at the low value of the sensor operating scale. This value must be displayed on the monitor with a tolerance of $\pm 0.5\%$ of the range of this scale.
- Proceed same with the high value of the scale.

If the values displayed on the monitor are out of the tolerances, modify the calibration with a 1 mm flat screwdriver:

- Supply with a pressure corresponding at the low value of the sensor operating scale.
- Gently drill the silicon protection upright the "zero" adjuster (check the label).
- Act upon the "zero" to bring the value displayed on the monitor in the tolerance.
- Supply with a pressure corresponding at the high value of the sensor operating scale.
- Proceed same with the "span" adjuster.
- Fill in again the holes of the adjuster protection with silicon grease.
- Install the sensor and its gasket.

Note: install carefully the gasket in its groove.

Close the terminal box cover by screwing the 6 screws, take care at the sealing gasket.

Pressure sensor calibration on pressure measurement model

- Remove the 4 fixing screws of the terminal box cover, using a 4 mm hexagonal key.
- Install the sensor on a tool connected to the output on a pneumatic calibrator.
- Supply with a pressure corresponding at the low value of the sensor operating scale. This value must be displayed on the monitor with a tolerance of $\pm 0.5\%$ of the range of this scale.
- Proceed same with the high value of the scale.

If the values displayed on the monitor are out of the tolerances, modify the calibration with a 1 mm flat screwdriver:

- Supply with a pressure corresponding at the low value of the sensor operating scale.
- Act upon the "zero" to bring the value displayed on the monitor in the tolerance.
- Supply with a pressure corresponding at the high value of the sensor operating scale.
- Proceed same with the "span" adjuster.
- Close the terminal box cover by screwing the 4 screws, take care at the sealing gasket.

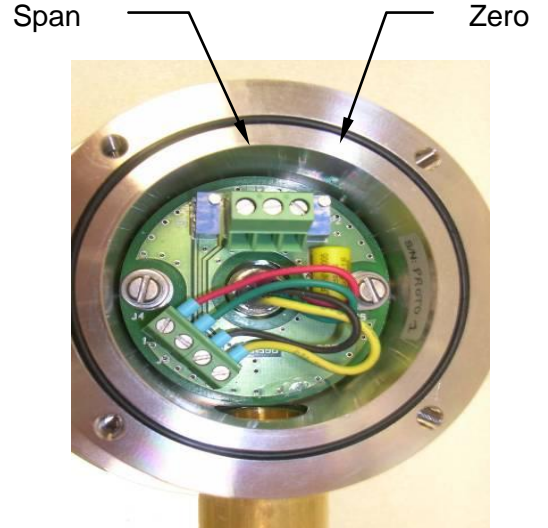

Pressure sensor replacement



Check the On/Off switch on the TA3840S safety unit front panel is in "Off" position (or TA840-I safety unit for the TA840 system).

Pressure sensor integrated in the T901-P temperature/pressure transmitter

- Remove the 6 fixing screws from the removable cover, using a 10 mm wrench.
- Disconnect the three electrical wires from the terminal. Note down each colour in order to be sure to reconnect them in the correct order.
- Unscrew the 2 fixing screws, using a 4 mm hexagonal key.
- Remove the pressure sensor.
- Install the new pressure sensor and its gasket, and reconnect in reverse order.

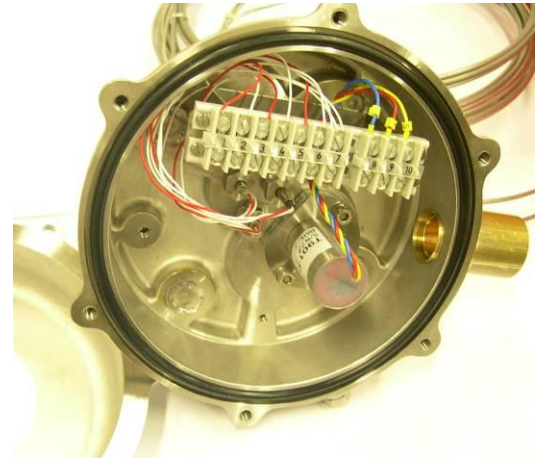

Note: install carefully the gasket in its groove.

To close the terminal box, check the sealing O-ring is in correct position in the groove. If necessary, put again some silicone grease on it, with fingers.

Place the cover in correct position and screw the 6 hexagonal head screws, using a 10 mm wrench.

Pressure sensor

Pressure sensor integrated in the EM940 radar

- Remove the 6 fixing screws from the terminal box cover, using a 10 mm wrench.
- Disconnect the three electrical wires from the terminal. Note down each colour in order to be sure to reconnect them in the correct order.
- Close the internal isolating valve.
- Unscrew the 2 fixing screws, using a 4 mm hexagonal key.
- Remove the pressure sensor.
- Install the new pressure sensor and its gasket, and reconnect in reverse order.
- Open the internal isolating valve.



Isolating valve of the pressure sensor

Note: install carefully the gasket in its groove.

To close the terminal box, check the flat gasket is in correct position. If necessary, put again some silicone grease on it, with fingers.

Place the cover in correct position and screw the 6 hexagonal head screws, using a 10 mm wrench. **TORQUE 5 N/m**

LOG3840 deck digital indicator - Repair procedures



Check the On/Off switch on the TA3840S safety unit front panel is in "Off" position (or TA840-I safety unit for the TA840 system).

 **Make sure that the new module is delivered by Honeywell Marine with the pre-set parameters related to the tank from which the indicator is to be replaced.**

Stainless steel casing model

- Unscrew the 4 M4 screws, located on the rear face, to remove the deck indicator casing, using a 2.5 mm hexagonal key.
- Disconnect the electrical wires from the terminal. Note down each colour in order to be sure to reconnect them in the correct order.
- Unscrew the 4 M3 screws to remove the electronic module, using a 2.5 mm hexagonal key.
- Install the new electronic module and reconnect in reverse order.
- If necessary, refer to the LOG3840 terminal wiring diagram in the MI5016E installation manual.
- Check the sealing O-ring condition. If necessary, change it and put some silicone grease with fingers.
- Place the deck indicator in correct position on the flange and screw the 4 M4 screws.

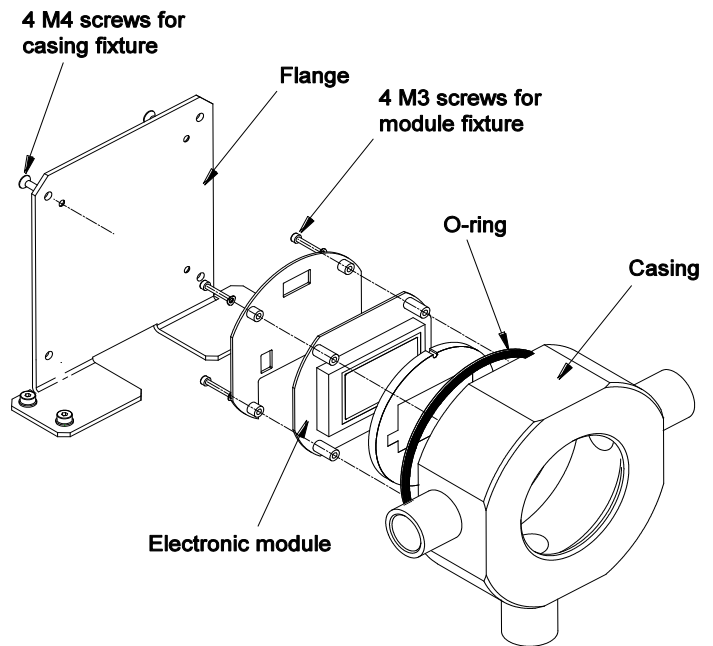

Polyester casing model

- Unscrew the 4 fixing screws of the cover with a flat screwdriver.
- Unscrew the 2 fixing screws of the bracket supporting the electronic module, with a flat screwdriver.
- Disconnect the electrical wires from the terminal. Note down each colour in order to be sure to reconnect them in the correct order.
- Unscrew the 4 M3 screws to remove the electronic module, using a 2.5 mm hexagonal key.
- Install the new electronic module and reconnect in reverse order.
- If necessary, refer to the LOG3840 terminal wiring diagram in the MI5016E installation manual.
- Check the cover gasket condition. If necessary, change it and put some silicone grease with fingers.
- Place the cover to close the deck indicator and screw the 4 fixing screws of the cover with a flat screwdriver.

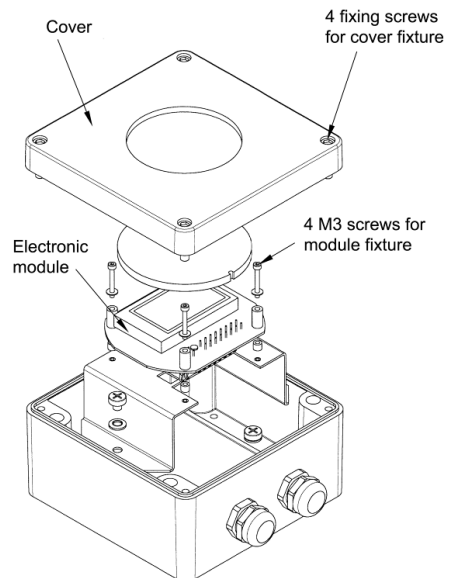

5. SPARE PARTS LIST

EMx40 radars

Components, with ordering codes:

Code	Designation
34636	EM540 radar V2.00 IMPORTANT: when ordering, specify the relevant tank to enable the pre-setting of the radar parameters in factory
35091 - X	EM540 radar V3.00 IMPORTANT: when ordering, specify the relevant tank to enable the pre-setting of the radar parameters in factory
34820 - X	EM940 radar IMPORTANT: when ordering, specify the relevant tank to enable the variant definition and the pre-setting of the radar parameters in factory
M13130	10" Nitril gasket for EM940 radar
34833	8" Nitril gasket for EM540 radar
965389	PTFE gasket (quantity needed: 2.5 m for EM940)
30137	Gasket for EM540 V3.00 and EM940 terminal box
35111	Gasket for EM540 V2.00 terminal box
34191	Sealing ring for BV2 packing-gland, for cable 7 to 12 mm
966666	Sealing ring for BV2 packing-gland, for cable 8.5 to 14.5 mm
34465	Sealing ring for BV3 packing-gland, for cable 8.5 to 14 mm
966667	Sealing ring for BV3 packing-gland, for cable 13 to 19 mm
M13422	Plug kit for BV2 packing-gland (brass)
M13423	Plug kit for BV3 packing gland (brass)
35112	Movable 4-point connector for EM540 V1.00 and V2.00
35474	Movable 5-point connector for EM540 V2.00
35113	Movable 7-point connector for EM540 V1.00 and V2.00
32868 - 6	Pressure sensor kit for EM940, range 800 to 2000 mbar, FFKM gasket
35114	Connecting board for EM540 V3.00 and EM940, with gasket
M12903 - 1	Bolt kit M20 x 100 for EM540
M13143	Bolt kit M20 x 80 for EM940

T901-P temperature/pressure transmitter

Components, with ordering codes:

Code	Designation
966516	Gasket for terminal box of universal model
30932	Temperature sensor IMPORTANT: when ordering, specify the relevant tank to give the correct length at the sensor tube in factory
32868 - X	Pressure sensor of universal model IMPORTANT: when ordering, specify the sensor scale and the gasket type
966513	10-point terminal
35156	Electronic board of pressure measurement model
34191	Sealing ring for BV2 packing gland, for cable 7 to 12 mm
966666	Sealing ring for BV2 packing gland, for cable 8.5 to 14.5 mm
34465	Sealing ring for BV3 packing gland, for cable 8.5 to 14 mm
966667	Sealing ring for BV3 packing gland, for cable 13 to 19 mm

LOG3840 deck digital indicator

Components, with ordering codes:

Code	Designation
	Gasket for stainless steel casing model
34909	Electronic module IMPORTANT: when ordering, specify the relevant tank to enable the pre-setting of the module parameters in factory
34191	Sealing ring for BV2 packing gland, for cable 7 to 12 mm
966666	Sealing ring for BV2 packing gland, for cable 8.5 to 14.5 mm
34465	Sealing ring for BV3 packing gland, for cable 8.5 to 14 mm
966667	Sealing ring for BV3 packing gland, for cable 13 to 19 mm
34919	Polyester casing model cover, with glass
	Stainless steel casing model body, with glass

6. INFORMATIONS

Claim report

The target is: help us to help you !

Despite the troubleshooting guide and the repair procedures, in case of spare part need or of request for service, the claim report in annex A needs to be fulfilled and transmitted by fax to **Honeywell Marine**. This will help us to confirm the nature of failure and remedies, for better service.

This report will be requested before any other intervention.

Return for repair

The return for repair form in annex B needs to be fulfilled and transmitted to **Honeywell Marine** together with the defective equipment in purpose. This will help us to identify the defect and the action to carry out, for better service.

Reference of Honeywell Marine customer service

Address:

HONEYWELL MARINE

9 rue Isaac Newton

Z.A. Port Sec Nord

18000 BOURGES - France

Telephone : +33 2 48 23 79 18

Fax : +33 2 48 23 79 02

E-mail : service.marine@honeywell.com

7. APPENDIX A - EMx40 SYSTEM / CLAIM REPORT

Vessel: Hull number:

Owner or Shipyard:

EM540 radar P/N:..... S/N:

EM940 radar P/N:..... S/N:

T901-P transmitter P/N:..... S/N:

LOG3840 indicator P/N:..... S/N:

Designation of the tank:

1) Description of trouble, with read values, messages, indicators status, alarms status, etc...:

2) Result of troubleshooting item applied, observations:

3) Carried out remedies:

4) Requested spare parts:

NAME:	DATE:
QUALITY:	SIGNATURE:

8. APPENDIX B – EMx40 SYSTEM / RETURN FOR REPAIR FORM

Honeywell		Return Material Authorization Form	
Formulaire S-SOP-FR1F-SRV-1-F01		Ship to:	Honeywell Marine 9, rue Isaac Newton ZA Port Sec Nord 18000 Bourges (FRANCE)
Handled by:		Est. shipping date:	
E-mail: Tel: +33 (0) 248237918 Fax: +33(0) 248237902		RMA #:	
		RMA # only issued by Honeywell Marine factory.	
Return shipment details		Customer order details	
Company name		Customer order ref #	
Attention		Quotation required?	<input type="checkbox"/> Yes <input type="checkbox"/> No
Address		Warranty claim details	
Postal code / City		Warranty claimed?	<input type="checkbox"/> Yes <input type="checkbox"/> No
Country		Reason of claim:	
Phone / Fax		Original order #:	
E-mail		Delivery date:	
Return shipment by:		Claim acceptance	<input type="checkbox"/> Yes <input type="checkbox"/> No
End user info			
End user same as Return shipment consignee?	<input type="checkbox"/> Yes <input type="checkbox"/> No	If not, provide end user company and description of end use:	End user company:
			End use:
Instrument / Item details			
Instrument description:			
Model # / Type #:			
Serial #:			
Part #:	Description:		
Installation date:	Commissioning date:		
Problem description:			
Goods are returned for:	<input type="checkbox"/> Repair <input type="checkbox"/> Replacement <input type="checkbox"/> Model # Change <input type="checkbox"/> (Re) Calibration <input type="checkbox"/> Return on Advanced Replacement <input type="checkbox"/> Upgrade / Modify <input type="checkbox"/> Other:		
Required modification/ calibration/change/etc.:			
Application details (applicable for wetted parts only)			
Product			
Operating temperature:	min.:	normal:	max.:
Operating pressure:	min.:	normal:	max.:
By signing and returning this RMA Form I confirm that the equipment has been cleaned and decontaminated in accordance with good industrial practices and in compliance with all regulations. This equipment poses no health or safety risk due to contamination. If applicable, I attach corresponding International Chemical Safety Cards for the media the equipment was exposed to.			
Also I agree that by returning above mentioned goods I will at least be charged with examination costs of EUR ,,,, per item.			
Name:			Signature:
Department:			
Date:			
In order to avoid delays please ensure that all applicable fields are completed. Completed forms (one per instrument, spares can be itemized on a separate list) to be mailed to service.marine@honeywell.com . Equipment to be sent to above mentioned "Ship To:" address with a copy of the completed form(s) on the packaging. Do not send equipment before receiving a RMA number.			

Honeywell Marine SAS

9, Rue Isaac Newton

18000 Bourges

France

Tel + 33 (0) 2 48 23 79 01

Fax + 33 (0) 2 48 23 79 03

E-mail: contact.marine@honeywell.com

www.honeywellprocess.com

MM5016E-rev05-ENG
February 2013
© 2013 Honeywell International Inc.

Honeywell