



NAR-KD-0151-1-en

SG2000

User Manual

Version: 1.01



SWIFT MARINE TECH SERVICES PTE LTD



Document Name

[NAR-KD-0151-1-en_SG2000_User_Manual.doc]

Associated documents and links

[]

Revision overview

Version	Date	Author	Changes
1.01	12.04.2016	SGa	transferred from Info 001E to this document Changed connection of terminal 7 in Fig. 1

printed in Germany

© 2016 NORIS Automation GmbH

This publication including any and all of its parts is copyrighted. Any exploitation or utilization of the text shall require prior written approval by NORIS Automation GmbH. This provision applies in particular to the reproduction, distribution, editing, translation, storage and / or processing of the material in electronic systems, including data bases and online services. Changes reserved.



Table of Contents

Associated documents and links	2
Revision overview	2
Table of Contents.....	3
Used Symbols	3
1 Introduction	4
2 Function.....	4
3 Principal scheme	5
3.1 Technical data	6
Table of Figures	7
Notes	8

Used Symbols



CAUTION

Attention! Very important instructions are following **to avoid damage to material.**

NOTE

Important notes are following.



READ

Here you will find cross-references to other documents with further information.

1 Introduction

The servo controller SG 2000 is provided to control hydraulic proportional valves with 2 solenoids and without position control.

The device is to be mounted in electrical cabinets or terminal boxes. It will be mounted with 4 screws directly at the mounting plate.

- Input signal**
- +/-10V DC as setting value
 - dry contact (NO) or +24V as enable signal
- output:**
- 2 proportional solenoids $I_{\max} = 1,5A$
 - Dry contact „Failure“ (NC)
 - Measuring outputs for setting and actual current (0-10V)
- Power supply:**
- 24V DC +30/-25%
- Signal-LED:**
- LED 1 green - no failure
 - LED 2 red - control loop fault
 - LED 3 red - voltage too low
 - LED 4 green - auxiliary voltage o.K.
 - LED 5 yellow- current limitation

2 Function

The controller works with 24V DC at the terminals 13 and 14. At terminals 1 and 2 the setting value of +/- 10VDC should be provided. If the enable signal at terminal 7 is present, the actual setting value is performed into a proportional current and feeded to the corresponding proportional solenoid, depending from the polarity of the input signal. The current is measured and controlled. The control of the solenoids is made as a PWM-signal. A so called jitter frequency, which is overlayed to the output current ensures, that the pistons of the valves will not glue. Depending from the polarity of the input signal, only the corresponding amplifier is switched on. The calibration of the output current is made by the manufacturer.

A failure output is performed in case of:

- Power supply voltage too low
- Auxiliary supply +15V is not present
- Failure in control loop (e.g. short circuit or wire braek)

At terminal 5 and 6 the actual current and the desired current can be measured as a 0 – 10V voltage.

3 Principal scheme

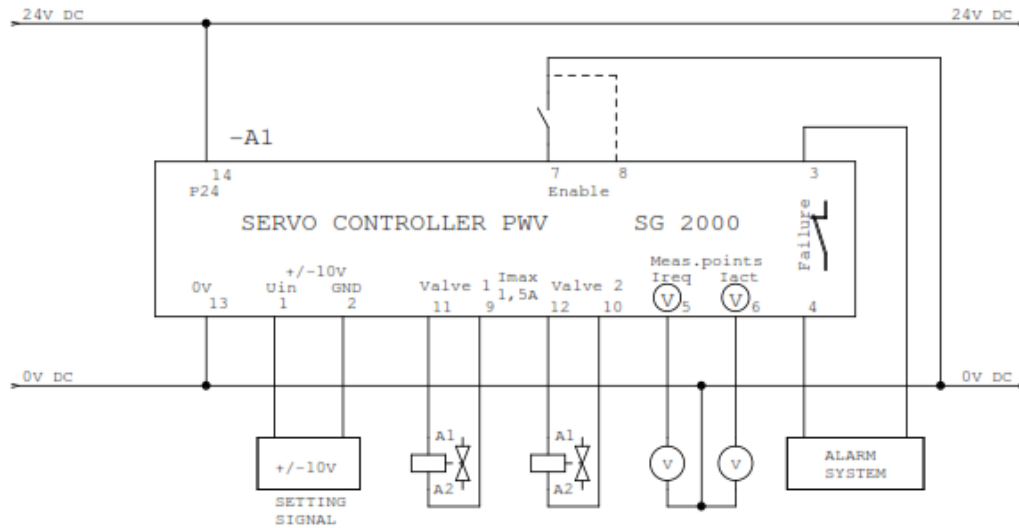

Fig. 1 principal scheme

CAUTION

The current sense for the solenoids is behind terminal 9 and 10, this connection is to be separated always.

In case of solenoid systems with 3- pole connection, use as common terminal 11 or 12 (+24V supply)

3.1 Technical data

Ambient temperature:	-20 °C - +70 °C
Climatic test:	IEC 60068-2-30
Storage temperature:	-45 °C - +85 °C
Power supply:	24V DC
Power supply range:	18 - 32V DC
Supply ripple:	up to 20%
Overvoltage:	2,5-times Urated für 2ms
Reverse supply protection:	integrated
Power consumption in idle conditions:	250 mA at 24V DC
Vibration:	0,7g acc. to IEC 60068-2-6; curve 2 (10Hz-100Hz)
EMC strength:	CE complied with
ESD	IEC 61000-4-2; Air discharge; +/- 8kV
Electromagnetic fields:	IEC 61000-4-3; 10V/m; 80%AM;1kHz; 0,01 ... 2000 MHz
Burst:	IEC 61000-4-4; coupling tongs; Supply +/-2kV
Surge:	IEC 61000-4-5; Asymmetrical; +/-2kV; Symmetrical +/-1kV
Mains-borne HF-disturbance:	IEC 61000-4-6, 3Vpp, 80%AM; 1kHz; 0,01 ... 2000MHz
Mains-borne LF-disturbance:	IEC 60553; 3Vpp; 0,05 ... 10 kHz
Interference field strength:	Basis CISPR 16-1, 16-2 and special curve GL
Case:	steel
Orientation:	any
mounting:	4 screws M4
electrical connections:	terminals 2,5 mm ²
degree of protection:	IP 00
weight:	400g



Table of Figures

Fig. 1 principal scheme5



